

Gefen

®

Extender for HDMI® 1.3 over CAT5 with Ethernet

EXT-HDMI1.3-CAT5-ELR
User Manual



ASKING FOR ASSISTANCE

Technical Support:

Telephone (818) 772-9100
(800) 545-6900

Fax (818) 772-9120

Technical Support Hours:

8:00 AM to 5:00 PM Monday thru Friday, Pacific Time

Write To:

Gefen, LLC.
c/o Customer Service
20600 Nordhoff St
Chatsworth, CA 91311

www.gefen.com
support@gefen.com

Notice

Gefen, LLC reserves the right to make changes in the hardware, packaging and any accompanying documentation without prior written notice.

Extender for HDMI 1.3 over CAT5 with Ethernet
is a trademark of Gefen, LLC

HDMI, the **HDMI** logo, and **High-Definition Multimedia Interface** are trademarks or registered trademarks of HDMI Licensing in the United States and other countries.

© 2010 Gefen, LLC, All Rights Reserved
All trademarks are the property of their respective owners

Rev A10
29.6

CONTENTS

- 1 Introduction
- 2 Operation Notes
- 3 Features
- 4 Sender Unit Layout
- 5 Sender Panel Descriptions
- 6 Receiver Panel Layout
- 7 Receiver Panel Descriptions
- 8 Connecting the Extender for HDMI 1.3 over CAT-5 with Ethernet
- 8 Wiring Diagram
- 9 Network Cable Wiring Diagram
- 10 DIP Switches
- 11 DIP Switch Settings
- 12 Mounting Plate Installation
- 13 Terminology
- 14 Specifications
- 15 Warranty

INTRODUCTION

Congratulations on your purchase of the Extender for HDMI 1.3 over CAT5 with Ethernet. Your complete satisfaction is very important to us.

Gefen

Gefen delivers innovative, progressive computer and electronics add-on solutions that harness integration, extension, distribution and conversion technologies. Gefen's reliable, plug-and-play products supplement cross-platform computer systems, professional audio/video environments and HDTV systems of all sizes with hard-working solutions that are easy to implement and simple to operate.

The Gefen Extender for HDMI 1.3 over CAT5 with Ethernet

The Extender for HDMI 1.3 over CAT5 with Ethernet extends a Hi-Def Display with multi-channel digital audio and Ethernet at resolutions of up to 1080p60 at up to 330 feet (100 meters) away from a HDMI or DVI-D Source using one CAT-5 cable.

DVI-D is supported when used with an HDMI to DVI Adapter, providing greater flexibility and options when integrating several home theater components. 3D content can be displayed when a 3DTV and 3D source are connected.

Extension of Ethernet connectivity enables internet or local area network access for HDTVs, home PCs, video game consoles, DVRs and any device that needs fast 10/100Base-T network access, at convenient locations.

The IR back-channel feature lets users control Hi-Def Sources as if they were located at the Display. IR commands are processed by the IR eye on the receiver, transmitted back over the CAT5 extension, and then sent to original A/V Source devices located by the sender unit using the IR Blaster (sold separately).

How It Works

Connect the Gefen Extender for HDMI 1.3 over CAT5 with Ethernet sender unit to the A/V and Ethernet Source devices such as infrastructure, routers and switches using short HDMI and CAT5 cables. Do the same operation between the Extender receiver and the extended HD Display and any network devices that you are connecting to. When the Extender sender and receiver units have been connected to Sources, Displays and network equipment, connect a single CAT5 extension cable between sender and receiver. The Extender sender and receiver units may be up to 330 feet apart.

Note: The Extender for HDMI 1.3 over CAT5 with Ethernet is fully HDMI and HDCP compliant.

OPERATION NOTES

READ THESE NOTES BEFORE INSTALLING OR OPERATING THE EXTENDER FOR HDMI 1.3 OVER CAT5 WITH ETHERNET

- The Extender for HDMI 1.3 over CAT5 with Ethernet units are housed in a metal box for better RF shielding.
- CAT-5 cables should not exceed 330 feet.
- Shielded CAT-6 with metal RJ-45 connectors are recommended to safeguard against random video flashes caused by electromagnetic interference (EMI).
- The Extender for HDMI 1.3 over CAT5 with Ethernet features the ability to generate compatible EDID and Hot Plug signals for troubleshooting purposes when dealing with difficult interfacing issues between Source devices and Displays. Refer to pages 9 and 10 for details.
- HDCP content is not supported when the unit is in DVI mode. See page 10 for details.

FEATURES

HDMI 1.3 Features

- 225 MHz (up to 12-bit YUV 444 @ 1080p)
- Deep Color
- Dolby TrueHD and DTS-HD Master Audio
- Lip-Sync
- CEC Pass-Through

Features

- Extends HDMI1.3 at 1080p60 over Ethernet up to 330 feet along with Ethernet and IR commands
- Built-in IR extender function allows IR remote control of Source devices from remote viewing location by sending IR commands received in the vicinity of the Display back to the Source devices
- 3DTV Pass-Through
- Supports high bit-rate multi-channel audio formats (Dolby TrueHD / DTS Master Audio) embedded in the HDMI 1.3 signal
- Fully HDMI and HDCP compliant
- Extends Ethernet protocol from a network switch to a device up to 330 feet away
- Locking power connectors on the Extender units and power supplies for secure connections
- Eliminates equipment noise in the viewing environment
- All-digital signal transmission over the CAT5 cable for zero signal loss
- Built-in auto video signal equalization
- EDID and Hot Plug signal generation features for troubleshooting difficult Source-Display interfacing issues.

Package Includes

- (1) Extender for HDMI 1.3 over CAT5 with Ethernet Sender Unit
- (1) Extender for HDMI 1.3 over CAT5 with Ethernet Receiver Unit
- (1) 6 ft. HDMI locking cable (M-M)
- (2) 5V DC Locking Power Supply
- (1) User Manual

SENDER UNIT LAYOUT

Front



Back

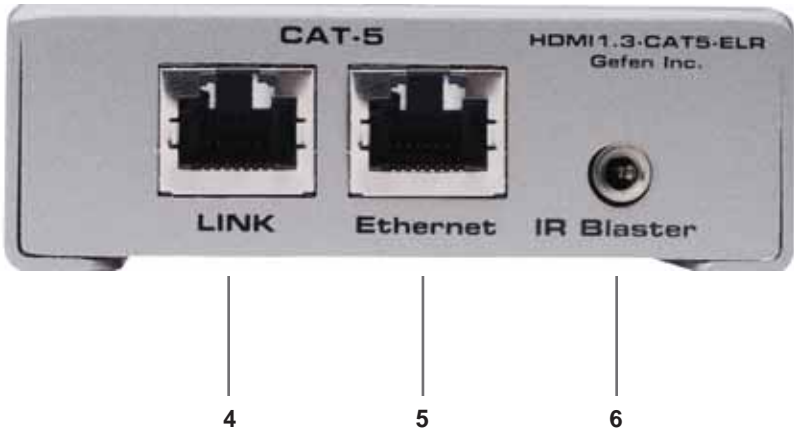

SENDER UNIT DESCRIPTIONS

1 5V DC Locking Power Connector

Connect the included 5V DC locking power supply to this connector. Only use the power supply shipped with this unit.

2 Power Indicator

This LED will turn bright red once the included 5V DC locking power supply has been properly connected to the unit and the locking power supply has been connected to an available wall outlet.

3 Locking HDMI Port

Connect a 3D Hi-Def source device to this HDMI port.

4 CAT-5 Output Jack

Connects the Sender to the Receiver unit using CAT-5 cabling.

5 Ethernet Input Jack

Connects the Sender to the network using Ethernet cabling.

6 IR Blaster Port

Connect an IR Blaster cable (Gefen part # EXT-2IREMIT) from this port to the Hi-Def source to control the source from the viewing location.

RECEIVER UNIT LAYOUT

Front



Back

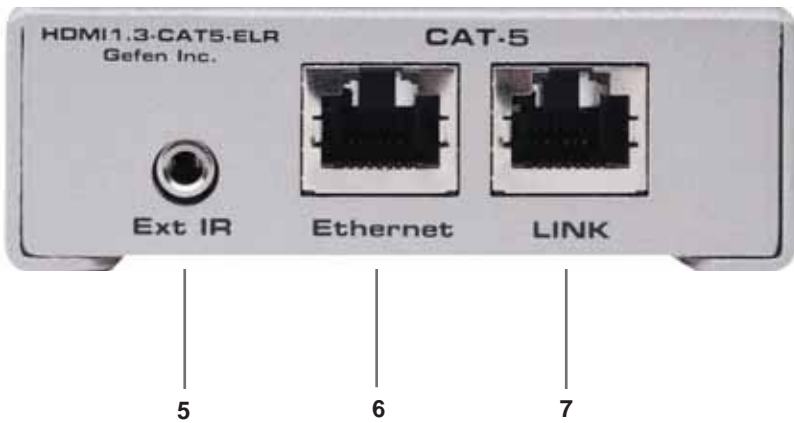

RECEIVER UNIT DESCRIPTIONS

1 IR Sensor

Receives signals from the Hi-Def source IR remote control. The IR signals are sent back to the source device, when using an IR Blaster on the Sender.

2 Locking HDMI Port

Connect a Hi-Def source device to this HDMI port.

3 Power Indicator

This LED will turn bright red once the included 5V DC locking power supply has been properly connected to the unit and the locking power supply has been connected to an available wall outlet.

4 5V DC Locking Power Connector

Connect the included 5V DC locking power supply to this connector. Only use the power supply shipped with this unit.

5 IR Extender Port

Connect an IR Extender (Gefen part # EXT-RMT-EXTIR) cable from this port to the Hi-Def source to extend the IR control.

6 Ethernet Output Jack

Connects the receiver unit to the network device.

7 CAT-5 Input Jack

Connects the Sender to the Receiver unit using CAT-5 cabling.

CONNECTING THE EXTENDER FOR HDMI 1.3 OVER CAT5 WITH ETHERNET

1. Connect the Hi-Def source to the Sender Unit using the included HDMI cable.
2. Use an HDMI cable to connect the HDTV display to the Receiver Unit.
3. Connect the Ethernet device/router to the Ethernet input port on the Sender unit using a CAT-5, CAT-5e or CAT-6 cable. Connect the Ethernet output port on the Receiver Unit to the remote device/router with a CAT-5, CAT-5e or CAT-6 cable.
4. Use a CAT-5 or CAT-6 cable up to 330 ft (100 meters) to connect the Sender Unit and Receiver Unit.

NOTE: If terminating network cables in the field, please adhere to the TIA/EIA568B specification. See Page 11 for details.

5. Connect the included 5V DC Locking Power Supplies to the Sender Unit and Receiver Unit. Do not overtighten the locking connectors. Plug the two power supplies into an available electrical outlet using the included AC power cords. The Sender and Receiver units will now power up.

NOTE: If the power LED indicator on the receiver unit is not on, check to make sure that the CAT5 cables are not crossed (Ethernet to Link instead of Ethernet to Ethernet, for instance).

6. Power on the HDTV display and the Hi-Def source. A vibrant HD picture will be displayed along with multichannel digital audio (if supported by the display).

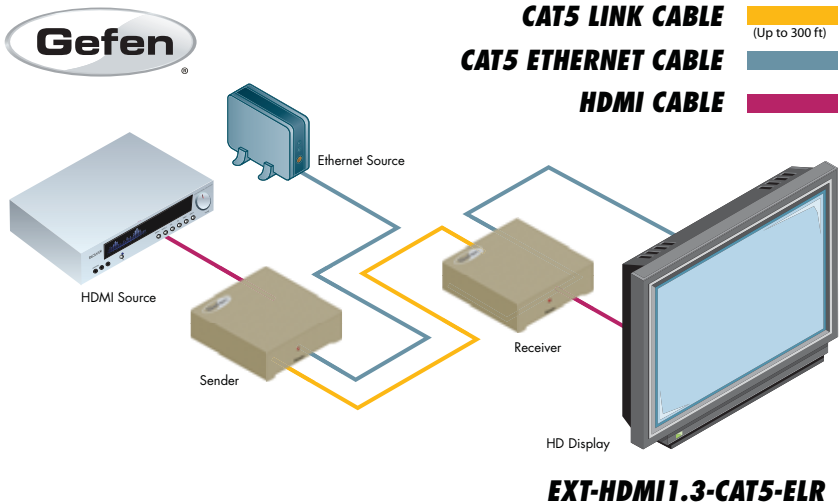

DIP SWITCHES

DIP Switch Location

On the bottom of the Extender for HDMI 1.3 with Ethernet Receiver unit there are four (4) DIP switches.

The DIP switches allow advanced EDID management of the Extender for HDMI 1.3 with Ethernet which may be necessary when troubleshooting or using different brands of hardware. The DIP switches allow control over the EDID and the HPD (Hot Plug Detect) status.

Receiver Unit (bottom)

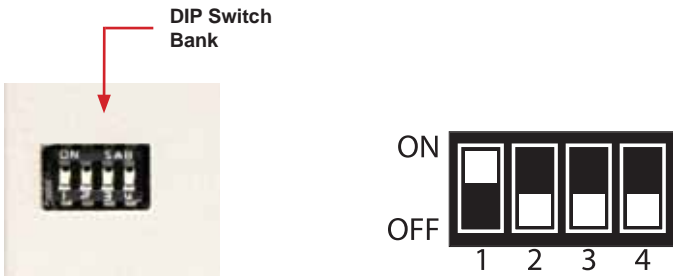

NOTE: DIP switch 4 is not used.

Default settings for DIP switches

DIP Switch	Position
1	ON
2	OFF
3	OFF
4	NOT USED

DIP SWITCH SETTINGS

DIP 1 - EDID Mode

ON (default) - External EDID Mode

- DDC and HPD are passed through. Both the connection status and the full A/V capabilities of the display. The HPD status will also be detected by the source device.

OFF - Internal EDID Mode

- Local EDID is used instead of the EDID from the display device. EDID features newer than HDMI 1.3 are removed when the display is read. This provides a general EDID which is compatible with more displays.

DIP 2 - Hot-Plug Detect

DIP switch 2 only works when DIP switch 1 is set to the OFF position.

ON - HPD Pass-Through

- HPD follows upstream HPD towards the source. The HPD signal will reflect the connection status between the display device and the source device. If the source or display is temporarily disconnected then reconnected, there will be a delay of 20 - 30 seconds before the A/V content is restored to the display.

OFF (default) - HPD Always High

- The HPD signal remains high regardless of the downstream HPD state. If the source or display device does not properly handle HPD (no picture after connecting / reconnecting source or display), set this DIP switch to the OFF position.

DIP 3 - Supports DVI Connections

ON

- Set DIP switch 3 to the ON position when using a DVI source or display. HDCP content is *not* supported in this mode.

OFF (default)

- If HDMI is connected, set DIP 3 in the OFF position.

NETWORK CABLE WIRING DIAGRAM

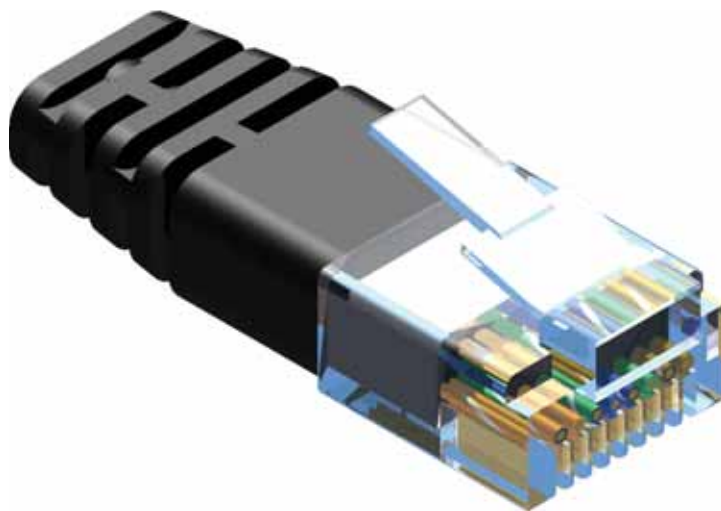

Gefen recommends the TIA/EIA-568-B wiring option. Please adhere to the table below when field terminating cable for use with Gefen products.

Pin	Color
1	Orange / White
2	Orange
3	Green / White
4	Blue
5	Blue / White
6	Green
7	Brown / White
8	Brown

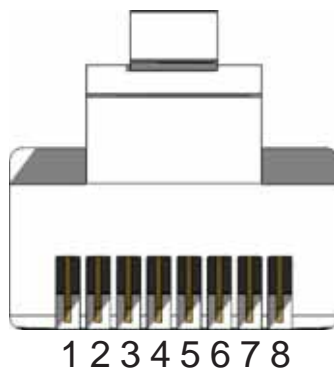

CAT-5, CAT-5e, and CAT-6 cabling comes in stranded and solid core types. Gefen recommends using solid core cabling. CAT-6 cable is also recommended.

It is recommended to use one continuous run from one end to the other. In some cases, connecting through a patch might not work.

MOUNTING PLATE INSTALLATION

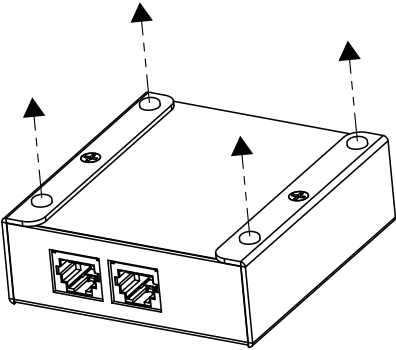

1

Remove the rubber feet covering the screws off the bottom of the unit.

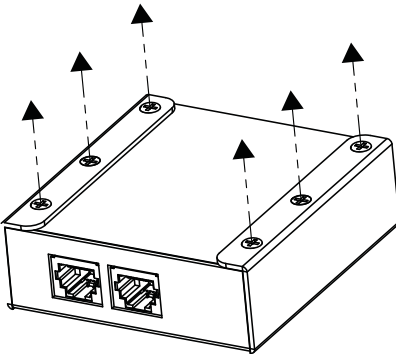

2

Remove the screws.

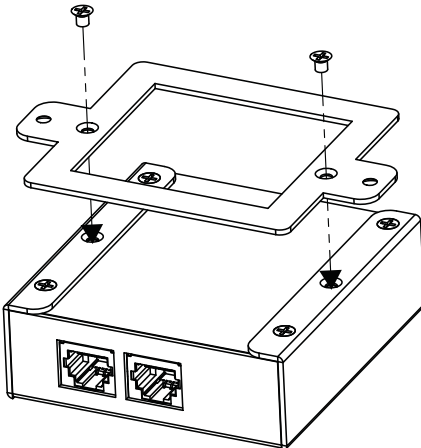

3

Line up the mounting plates and screw it on to the unit.

TERMINOLOGY

CAT-5/CAT5e

Category 5 cable, commonly known as Cat 5, is an unshielded twisted pair type cable designed for high signal integrity. The actual standard defines specific electrical properties of the wire, but it is mostly known as being rated for its Ethernet capability of 100 Mbit/s. Its specific standard designation is EIA/TIA-568. Cat 5 cable typically has 3 twists per inch of each twisted pair of 24 gauge copper wires within the cable. **CAT-5e** is similar to Cat 5 cable, but is enhanced to support speeds of up to 1000 Megabits/sec.

DDWG

Digital Display Working Group DDWG are the creators of the DVI specification.

DVI

Digital Visual Interface. A digital video standard established by DDWG, designed to carry uncompressed digital video signals to a Display.

HDMI

The High-Definition Multi-media Interface (HDMI) is an industry-supported, uncompressed, all-digital audio/video interface. HDMI provides an interface between any compatible digital audio/video Source, such as a set-top box, DVD player, and A/V receiver and a compatible digital audio and/or video monitor, such as a digital television (DTV).

HDCP

High-Bandwidth Digital Content Protection. Created by Intel, HDCP is used with HDTV signals over HDMI and HDMI connections and on D-Theater D-VHS recordings to prevent unauthorized duplication of copy written material.

HDTV

High-Definition Television. The high-resolution subset of our DTV system. The ATSC defines HDTV as a 16:9 image with twice the horizontal and vertical resolution of our existing system, accompanied by 5.1 channels of Dolby Digital audio. The CEA defines HDTV as an image with 720 progressive or 1080 interlaced active (top to bottom) scan lines. 1280:720p and 1920:1080i are typically accepted as high-def scan rates.

HPD

Hot Plug Detect. HPD is an electronic status signal which is used to signal the presence of absence of a Display device on the output of a digital audio/video interface, usually an A/V media player, scaler, splitter, etc.

EDID

Electronic Data Information Display. EDID is an electronic ID containing the capabilities of an audio/video output device such as an HDTV. Source devices will read the EDID of a Display or output device in order to know what resolution(s) should be used to draw a picture and how many channels to use when playing audio.

DDC

Display Data Channel. Provides information which allows rendering of a video picture.

SPECIFICATIONS

Video Amplifier Bandwidth	225 MHz
Input Video Signal	1.2 Volts p-p
Input DDC Signal	5 Volts p-p (TTL)
Max. Video Resolution Supported	1080p60 / 1920x1200@60 Hz
Max. Ethernet Data Transfer Rate.....	100 Mbps
Ethernet Packet Transmission Mode (Duplex):	Full
HDMI Input/Output Connector Type	Type A 19 Pin Female
Link Connector	RJ-45 Shielded
Power Input Connector :	5V DC locking jack
Power indicator LED:	Red (active when unit is powered)
Power Consumption	10 Watts (max) per unit
Power Supply	5V DC
Dimensions	3.4" D x 3.25" W x 1.25" H
Shipping Weight	3 lbs.

WARRANTY

Gefen warrants the equipment it manufactures to be free from defects in material and workmanship.

If equipment fails because of such defects and Gefen is notified within two (2) years from the date of shipment, Gefen will, at its option, repair or replace the equipment, provided that the equipment has not been subjected to mechanical, electrical, or other abuse or modifications. Equipment that fails under conditions other than those covered will be repaired at the current price of parts and labor in effect at the time of repair. Such repairs are warranted for ninety (90) days from the day of reshipment to the Buyer.

This warranty is in lieu of all other warranties expressed or implied, including without limitation, any implied warranty or merchantability or fitness for any particular purpose, all of which are expressly disclaimed.

1. Proof of sale may be required in order to claim warranty.
2. Customers outside the US are responsible for shipping charges to and from Gefen.
3. Copper cables are limited to a 30 day warranty and cables must be in their original condition.

The information in this manual has been carefully checked and is believed to be accurate. However, Gefen assumes no responsibility for any inaccuracies that may be contained in this manual. In no event will Gefen be liable for direct, indirect, special, incidental, or consequential damages resulting from any defect or omission in this manual, even if advised of the possibility of such damages. The technical information contained herein regarding the features and specifications is subject to change without notice.

For the latest warranty coverage information, please visit Gefen's Warranty web page at <http://www.gefen.com/kvm/aboutus/warranty.jsp>

PRODUCT REGISTRATION

Please register your product online by visiting Gefen's web site at <http://www.gefen.com/kvm/Registry/Registration.jsp>



Rev A10
29.6

20600 Nordhoff St., Chatsworth CA 91311

1-800-545-6900 818-772-9100 fax: 818-772-9120

www.gefen.com support@gefen.com

